

EFP 2000 EG

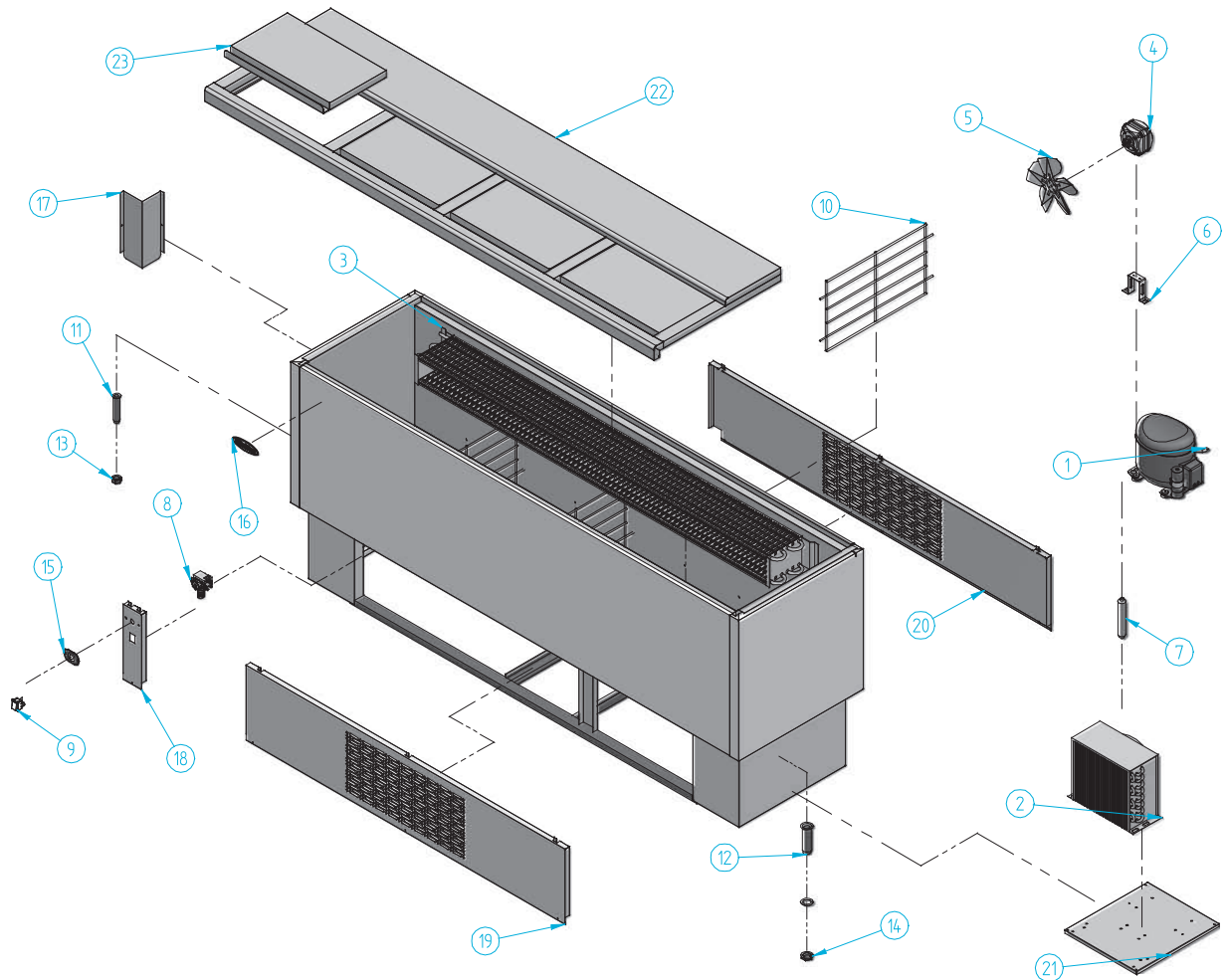

Nº	Código	Descripción	Cantidad
1	301D04	COMPRESOR 1/4 R134a	1
2	302X05	CONDENSADOR 8X3 CON BAFLE	1
3	303B03	EVAPORADOR EB/EFP 2000	1
4	304X02	MOTOVENT, 5W, IH-75 D-200l	1
5	304X06	PALA 200 mm	1
6	304X09	PIE MEDIANO (72 mm)	1
7	305X02	FILTRO 30 GR, 1/4 X 1/4 R-134a	1
8	308X10	TERMOSTATO	1

Nº	Código	Descripción	Cantidad
9	405X04	INTERRUPTOR GENERAL	1
10	504X26	SEPARADOR BOTELLEROS	3
11	603X15	DESAGUE 1/2 LARGO (COMPLETO)	1
12	603X16	DESAGUE 3/4	1
13	603X73	TUERCA 1/2	1
14	603X74	TUERCA 3/4 GAS	1
15	901X17	PEGATINA TERMOSTATO	1
16	901X57	MARCA INFRIECO RELIEVE 115x40 ROJO	1

Nº	Código	Descripción	Cantidad
17	EF10P14	PROTECTOR ASPIRACIÓN EFP EG	1
18	EF10P17P	C/MANDOS EFP EG	1
19	EF20P18P	REJILLA DELANTERA EFP 2000 EG	1
20	EF20P19	REJILLA TRASERA EFP 2000	1
21	EFP2000	BANCADA EFP2000	1
22	ENCEFP20EG	ENCIMERA EFP 2000 EG	1
23	PUEEB15	PUERTA BOTELLERO EB	4

