

VMS 1500 MAD

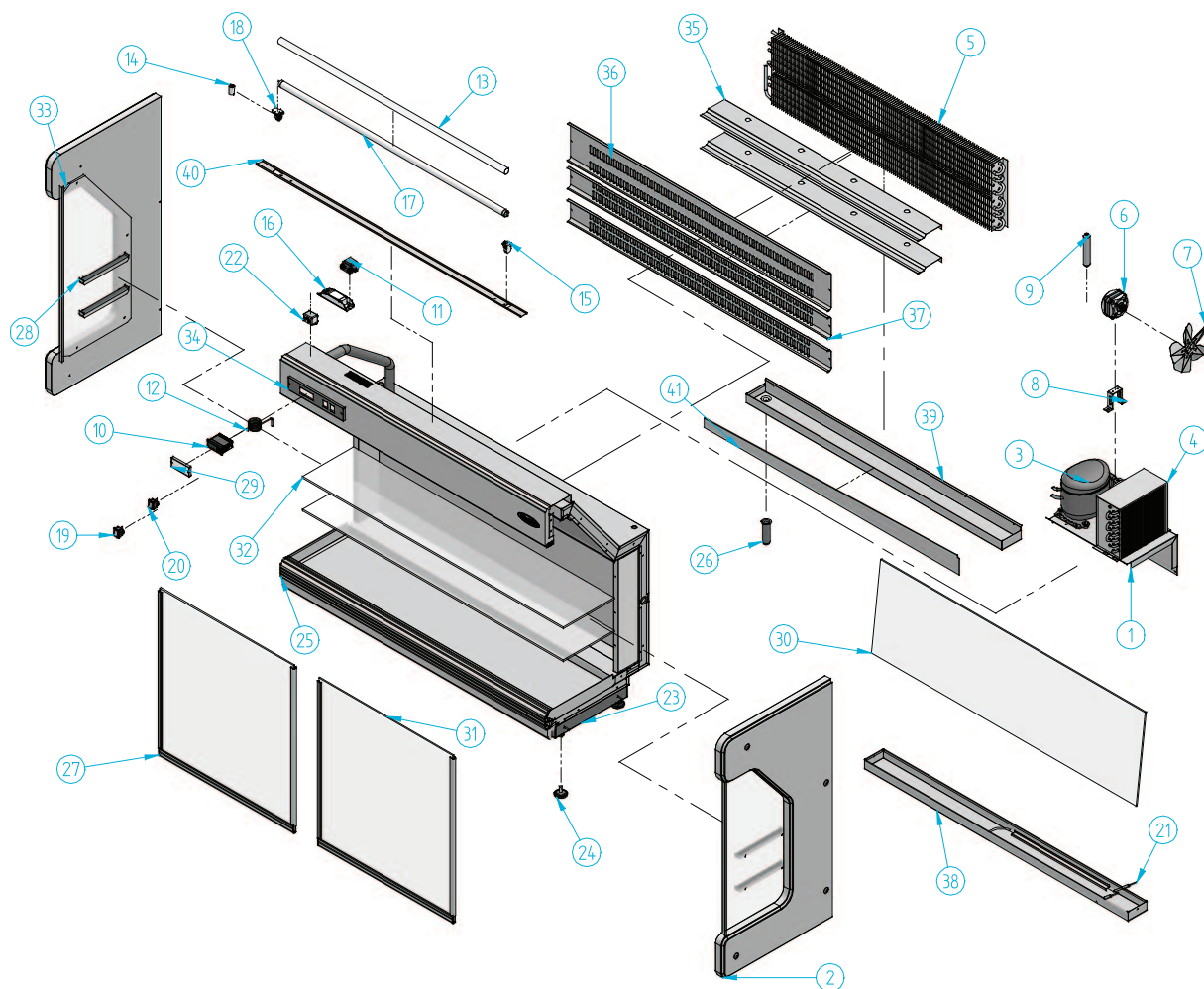

Nº	Código	Descripción	Cantidad
1	10VMSBANC	BANCADA VMS	1
2	203X85	COSTADO DCH VMS MADERA	1
3	301D04	COMPRESOR 1/4 R134a	1
4	302X05	CONDENSADOR 8X3 CON BAFLE	1
5	303V02	EVAPORADOR VMS 1500	1
6	304X02	MOTOVENT, 5WJH-75 D-200l	1
7	304X06	PALA 200 mm	1
8	304X09	PIE MEDIANO (72 mm)	1
9	305X02	FILTRO 30 GR. 1/4X1/4 R-134a	1
10	308X01	MICROPROC. 1 RELE XR20C 12 v	1
11	308X12	TRANSFORMADOR (220/12V)	1
12	308X16	SONDA MICROP. NTC 1.5 M	1
13	401X04	AKO TUBO 36 w	1
14	401X07	CEBADOR 4-80 w FS-11	1

Nº	Código	Descripción	Cantidad
15	401X12	PORTA-TUBOS (REF. 249/TS)	1
16	401X17	REACTANCIA 36-40 W (MS 3623)	1
17	401X25	TUBO FLUOR. 36W L.D. 1200 mm 26 Ø	1
18	401X28	PORTA-TUBOS +PI/CEBADOR 249/TCR	1
19	405X02	INTERRUPTOR NARANJA ILUMINACION	1
20	405X04	INTERRUPTOR GENERAL	1
21	406X06	RESISTENCIA VMS 220 v 200 w	1
22	407X14	FILTRO MONOFAS 250 V 3A FEH-3Z	1
23	505X32	RODAPIE VMS	2
24	506X25	REGULADOR M12	4
25	601X17	PERFIL REF-818 PLATA	1
26	603X16	DESAGUE 3/4	2
27	603X35	ROLDANA REF. HR0L 100	4
28	603X37	SOPORTE BAZAR VMS	4

Nº	Código	Descripción	Cantidad
29	603X83	PROTECTOR FRONTAL MICRO	1
30	604V79	LUNA VMS 1500 1400 x 407 x 5	1
31	604V82	PUERTA VMS 1350 710 x 747 x 6	2
32	604V85	BAZAR VMS 1500 1380 x 270 x 8	2
33	604V86	COSTADO CRISTAL VMS	2
34	C-M	C/MANDOS VMS	1
35	VMS-14	BAFLE VMS 1500	2
36	VMS-17	PROTECT EVAP SUP VMS 1500	1
37	VMS-17A	PROTECT EVAP MEDIO VMS 1500	2
38	VMS-23	BANDEJA EVAPORATIVA VMS 1500	1
39	VMS-27A	BANDEJA DESAGUE	1
40	VMS1500	PANTALLA VMS 1500	1
41	VMS15F1	EMBELLECEDOR BANDEJA	1

