

AN 1605 T/F

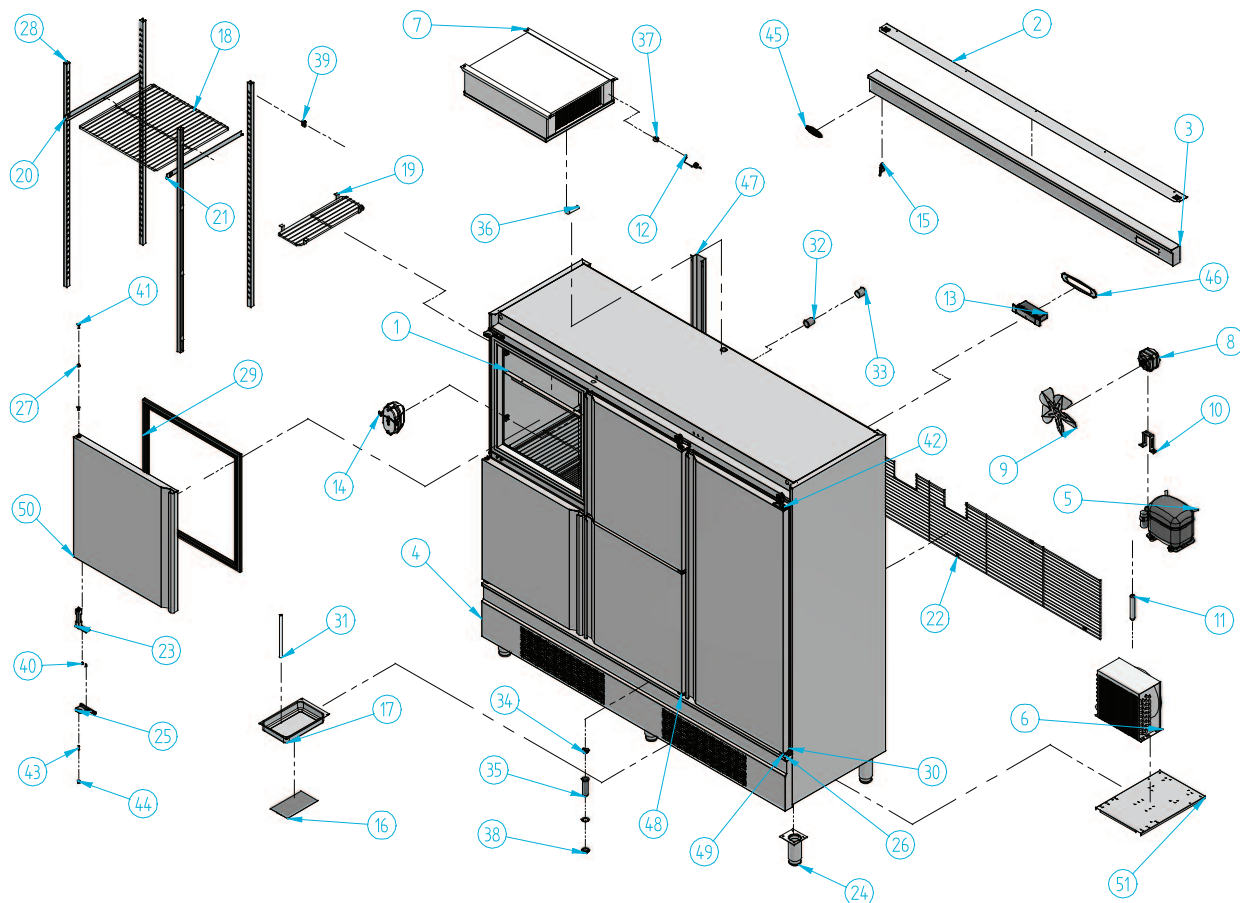

Nº	Código	Descripción	Cantidad
1	10AN1051	REJILLA VENT. EVAPORADOR AN	3
2	10AN1658	REJILLA VENT. C/MANDOS AN 1600	1
3	10AN1667	C/MANDOS AN 1600	1
4	10AN1680	REJILLA VENT. DEL AN 1600	1
5	301008	COMPRESOR 5/8 134A	1
6	302X10	CONDENSADOR 9x4 CON BAFLE	1
7	303T05	EVAPORADOR AN 1600	1
8	304X01	MOTOVENT. 10W IH-88 D-250I	1
9	304X07	PALA 250 mm	1
10	304X10	PIE GRANDE (84 mm)	1
11	305X02	FILTRO 30 GR. 1/4X1/4 R-134a	1
12	308X04	SONDA MICROPROC. NTC	2
13	308X11	MICROPROC. 2 RELE	1
14	401X06	APLIQUE OVAL C/P REF. 1400 G	2
15	405X10	MICRO DE PUERTA	3
16	406X32	PLACA RESIT. 200 w TERMOST.	1
17	501X29	BANDEJA EVAP. AN/VIT 398 x 190	1

Nº	Código	Descripción	Cantidad
18	502X02	PARRILLA AN 1000 PLAST.	9
19	502X21	SUPLEM. PARRILLA AN	6
20	503X12	GUIA PARRILLA AN 1000 (521 mm I	9
21	503X17	GUIA PARRILLA AN 1000 (521 mm I	9
22	504X13	REJILLA INF. UL COND. AN 1600	1
23	506X03	BISAGRA PUERTA	6
24	506X42	PATA REG. ARMARIOS 2 PULGADAS	6
25	506X54	SOPORTE BISAGRAS IZQUIERDO	3
26	506X55	SOPORTE BISAGRA DERECHO	5
27	506X56	TUERCA ANCLAJE	2
28	601X50	SOPORTE PARRILLA BAJO 03	12
29	602A01	BURLETE AN CHICA 631 x 665	4
30	602A02	BURLETE GRANDE AN 631 x 1396	1
31	602X29	GOMA DESAGUE 14 x 10 mm	1
32	603X124	PASA-MUROS INTERIOR	1
33	603X125	PASA-MUROS EXTERIOR	1
34	603X127	TAPON PARA DESAGUE 3/4	1

Nº	Código	Descripción	Cantidad
35	603X16	DESAGUE 3/4	1
36	603X33	PIPETA	1
37	603X40	SOPORTE BULBO	1
38	603X74	TUERCA 3/4 GAS	1
39	603X77	SOPORTE "U" DESMONTABLE	48
40	701X28	TORNILLO. 4,8x16 DIN 7982 NIOQUEL	36
41	701X62	TORNILLO M6x20 ULS (DIAM.13,6) A-2	2
42	701X63	TORNILLO M6x10 ULS (DIAM.13,6) A-2	4
43	701X64	ESPARRAGO M6 x 25 DIN 913 A-2	2
44	704X03	TUERCA REMACHABLE M6x9x14,5 AL/H	4
45	901X57	MARCA INFRICO RELIEVE 115x40 ROJO	1
46	901X58	PROTECTOR C/MANDOS FIG. A PLATA	1
47	AN1038	PROTECTOR ASPIRACION AN	1
48	PUEDCAN	PUERTA DCH CHICA AN	2
49	PUEDGAN	PUERTA DCH GRANDE AN	1
50	PUEICAN	PUERTA IZQ CHICA AN	2
51	VITBANC	BANCADA VITBANC	1

